

UNDERGROUND FIRE HYDRANT YERALTI YANGIN HİDRANTI

DemirVana

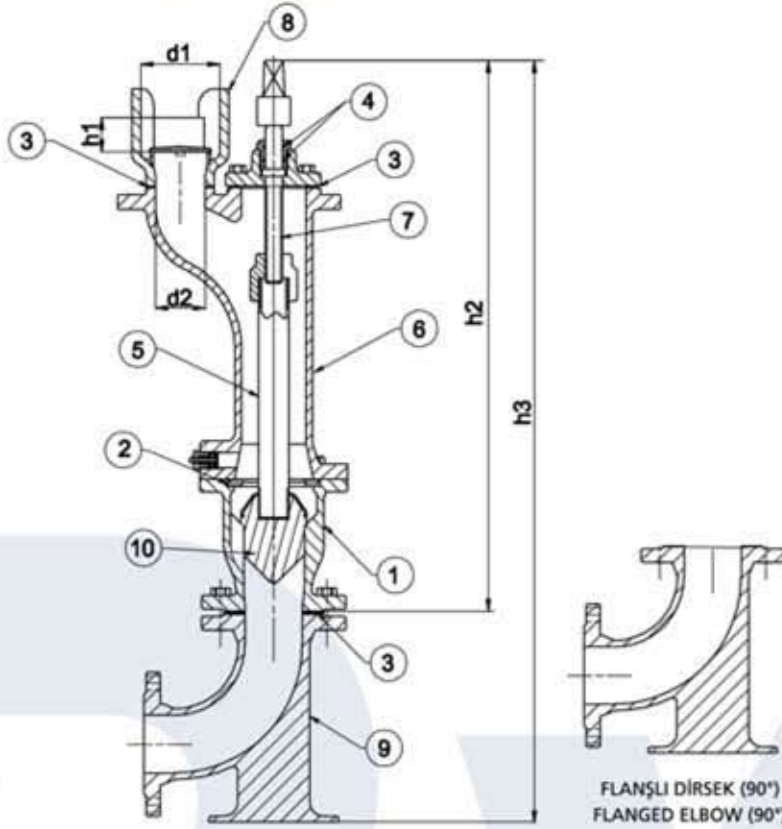

MALZEME ÖZELLİKLERİ / MATERIALS

PARÇA NO	PARÇA ADI	PART NAME	MALZEME	MATERIAL
1	ALT GÖVDE	VALVE CASING	GG25	GG25
2	SİT	BODY SEAT	Ms 58	Ms 58
3	CONTALAR	GASKETS	EPDM	EPDM
4	O-RİNGLER	O-RINGS	EPDM	EPDM
5	HAREKET BORUSU	ACTIVATING TUB	St 37	St 37
6	ÜST GÖVDE	BODY	GG25 - GGG40 / 50	GG25 - GGG40 / 50
7	MİL	STEM	PASLANMAZ ÇELİK	STAINLESS STEEL
8	KAPAK	OUTLET COVER	GG25	GG25
9	FLANŞLI DİRSEK 90°	FLANGED ELBOW	GG25	GG25
10	KLAPE	SEAT SEAL	GGG40+EPDM	GGG40+EPDM

YER ALTI YANGIN HİDRANTI / Underground Hydrant

DN	d1	d2	h1	h2	h3	Ağırlık / Weight (kg.)
80	110	75	50	750	1015	66

Hidrانت Ölçüsü Hydrant Dimension	Çıkış Ölçüsü Outlet Dimension	KV Flowrate (m ³ /h)
		Tek Çıkış Single
DN 80	1 x DN 75	120

SICAKLIK / BASINÇ TEMPERATURE / PRESSURE		UYGULAMALAR • Yangın tesisatlarında	APPLICATIONS • Fire fighting Systems
° C	-10..... + 120		
PN	16		



Demir Vana ve Kontrol Elemanları Makina San. Tic. Ltd. Şti

Merkez Ofis : İkitelli OSB Pik Dökümcüler San.Sit CA Blok No:3 Başakşehir/İstanbul

Tel : +90 212 297 57 30 Fax : +90 212 297 57 33 E-mail : dv@demirvana.com Web: www.demirvana.com