

OVERBOARD VALVE SPRING LOADED DIŞARJ VANASI YAYLI TİP

DemirVana

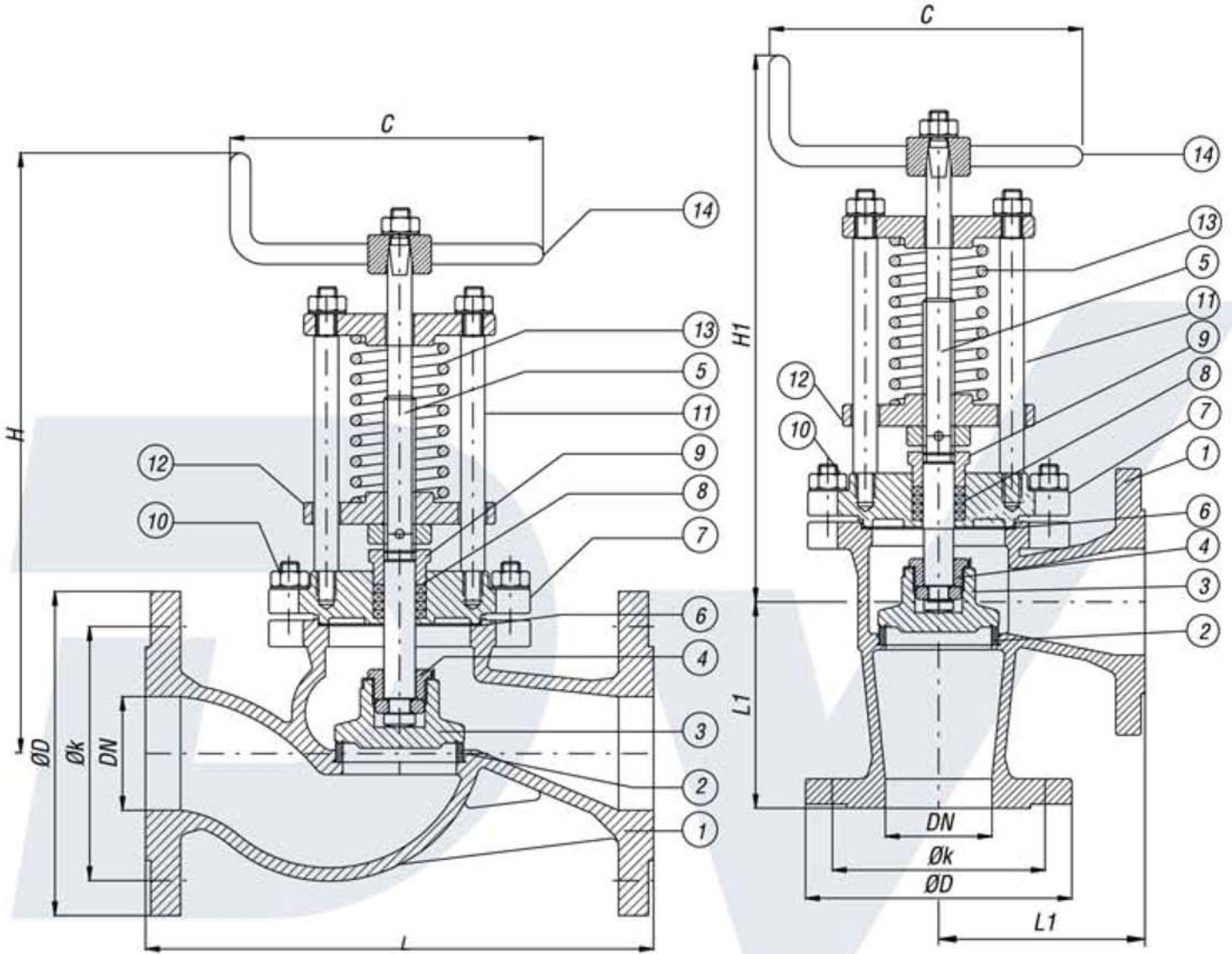

NO	PART NAME	PARÇA ADI	MATERIAL / MALZEME
01	Body	Gövde	GG 25/GGG-40/GS-C 25
02	Seat ring	Burc	1.4301/BRONZE
03	Disc	Klape	1.4301/BRONZE
04	Disc nut	Baskı	Ms 58
05	Spindle	Mil	1.4021/Cu Sn8
06	Gasket	Conta	Klingerite/Asberit
07	Bonnet	Kapak	GG 25/GGG-40/GS-C 25
08	Packing	Salmastra	Graphite
09	Gland	Sal.baskısı	GG 25/GGG-40/GS-C 25
10	Stud.nut	Saplama Somun	5.6-8
11	Pilar	Destek	Automat Steel
12	Bridge	Köprü	GG 25
13	Spring	Yay	AISI 301
14	Handwheel	El Çarkı	GG 25

DN	L	L1	H	H1	Strok	ØC	PN16				PN40			
							ØD	Øk	Ağırlık kg Düz Straight	Açılı Angle	ØD	Øk	Ağırlık kg Düz Straight	Açılı Angle
15	130	90	340	310	8	120	95	65	6.75	6.50	95	65	8	7
20	150	95	345	325	8	120	105	75	7	6.75	105	75	8.5	7.5
25	160	100	350	320	12	140	115	85	8	7	115	85	9	8
32	180	105	355	323	15	140	140	100	10	9	140	100	9.5	10
40	200	115	365	335	20	160	150	110	14	10	150	110	16.5	12
50	230	125	375	340	20	160	165	125	16	14	165	125	18	15
65	290	145	480	450	27	180	185	145	20	18	185	145	22.5	22
80	310	155	500	465	31	200	200	160	32	30	200	160	36	33
100	350	175	525	480	35	225	220	180	41	39	235	190	44.5	42
125	400	200	620	515	49	250	250	210	60	53	270	220	66	65
150	480	225	760	685	53	300	285	240	90	70	300	250	115	95
200	600	275	810	745	72	400	340	295	145	110	375	320	175	170
250	730	325	860	775	80	520	405	355	245	125	450	385	275	155
300	850	375	880	790	100	520	460	410	380	200	515	450	410	250



Demir Vana ve Kontrol Elemanları Makina San. Tic. Ltd. Şti

Merkez Ofis : İkitelli OSB Pik Dökümcüler San.Sit CA Blok No:3 Başakşehir/İstanbul

Tel : +90 212 297 57 30 Fax : +90 212 297 57 33 E-mail : dv@demirvana.com Web : www.demirvana.com