

QUICK CLOSING VALVE / ANGLE ANİ KAPAMA VANASI / KÖŞE

DemirVana

- 1 BODY
- 2 SEAT
- 3 DISC
- 4 SPRING
- 5 SEAL HOUSING
- 6 O-RING SEAL
- 7 STEM
- 8 UPPER PART
- 9 RELEASE CYLINDER
- 10 HANDWHEEL

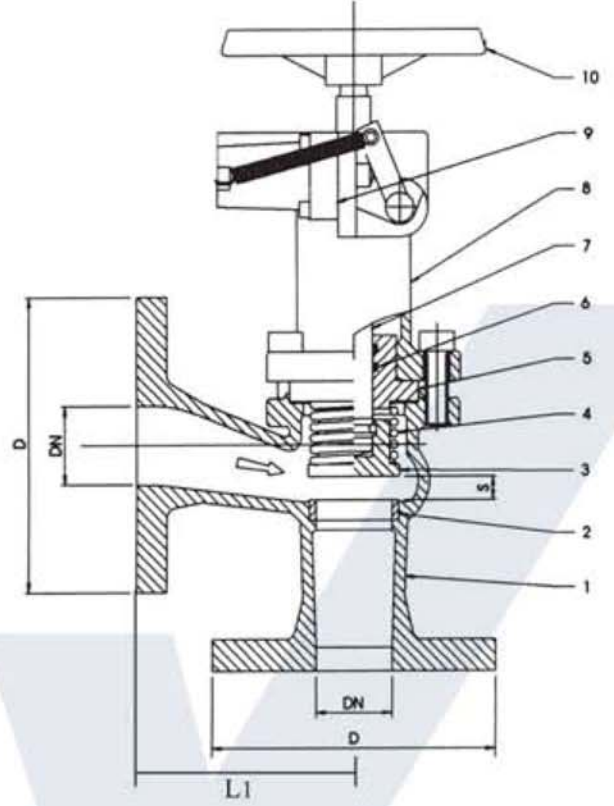

Material: Body in Nodular Cast iron GGG40.3
Seat/Disc/Stem in Stainless steel SS316
O-ring seal in Viton

Other dimensions/materials on request

DN	D	n	Hcd	d	L	Max working-pressure		Weight Kg
						Mpa 120 °C	Mpa 180 °C	
15	95	4	65	14	90	1,6	1,0	5,0
20	105	4	75	14	95	1,6	1,0	5,6
25	115	4	85	14	100	1,6	1,0	6,4
32	140	4	100	18	105	1,6	1,0	8,3
40	150	4	110	18	115	1,6	1,0	12,2
50	165	4	125	18	125	1,6	1,0	14,2
65	185	4	145	18	145	1,6	1,0	18,8
80	200	8	160	18	155	1,6	1,0	25,5
100	220	8	180	18	175	1,6	1,0	41,0
125	250	8	210	18	200	1,6	1,0	47,5
150	285	8	240	22	225	1,6	1,0	65,0
200	340	8	295	22	275	1,0	0,6	165,0
250	395	12	350	22	325	1,0	0,6	208,0



Demir Vana ve Kontrol Elemanları Makina San. Tic. Ltd. Şti

Merkez Ofis : İkitelli OSB Pik Dökümcüler San.Sit CA Blok No:3 Başakşehir/İstanbul

Tel : +90 212 297 57 30 **Fax :** +90 212 297 57 33 **E-mail :** dv@demirvana.com **Web:** www.demirvana.com