

# QUICK CLOSING VALVE / STRAIGHT ANİ KAPAMA VANASI / DÜZ

**DemirVana**

- |                  |                     |
|------------------|---------------------|
| 1 Valve housing  | 12 Screw            |
| 2 Disc           | 13 Screw            |
| 3 Spring         | 14 Setting nut      |
| 4 Disc nut       | 15 Release cylinder |
| 5 Ball           | 16 Upper part       |
| 6 Gasket         | 17 Release lever    |
| 7 O-ring housing | 18 Circlip          |
| 8 O-ring         | 20 Hand wheel       |
| 9 Screw          | 21 Washer           |
| 10 Stem          | 22 Nut              |
| 11 Indicator     |                     |

**Material:** Body in Nodular Cast iron GGG40.3  
Seat/Disc/Stem in Stainless steel SS316  
O-ring seal in Viton

Other dimensions/materials on request

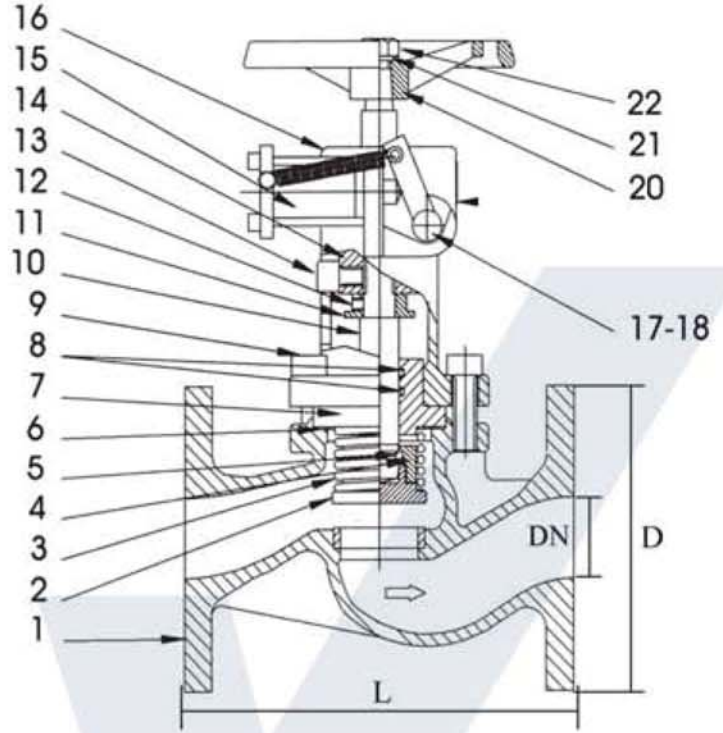

DN	D	n	Hcd	d	L	Max working-pressure		Weight Kg
						Mpa 120 °C	Mpa 180 °C	
15	95	4	65	14	130	1,6	1,0	3,5
20	105	4	75	14	150	1,6	1,0	4,0
25	115	4	85	14	160	1,6	1,0	5,0
32	140	4	100	18	180	1,6	1,0	6,8
40	150	4	110	18	200	1,6	1,0	9,3
50	165	4	125	18	230	1,6	1,0	12,2
65	185	4	145	18	290	1,6	1,0	18,0
80	200	8	160	18	310	1,6	1,0	25,0
100	220	8	180	18	350	1,6	1,0	35,0
125	250	8	210	18	400	1,6	1,0	55,0
150	285	8	240	22	480	1,6	1,0	77,0
200	340	8	295	22	600	1,0	0,6	145,0
250	395	12	350	22	730	1,0	0,6	243,0



**Demir Vana ve Kontrol Elemanları Makina San. Tic. Ltd. Şti**

**Merkez Ofis :** İkitelli OSB Pik Dökümcüler San.Sit CA Blok No:3 Başakşehir/İstanbul

**Tel :** +90 212 297 57 30 **Fax :** +90 212 297 57 33 **E-mail :** dv@demirvana.com **Web :** www.demirvana.com