

GATE VALVES SÜRGÜLÜ VANA

DemirVana

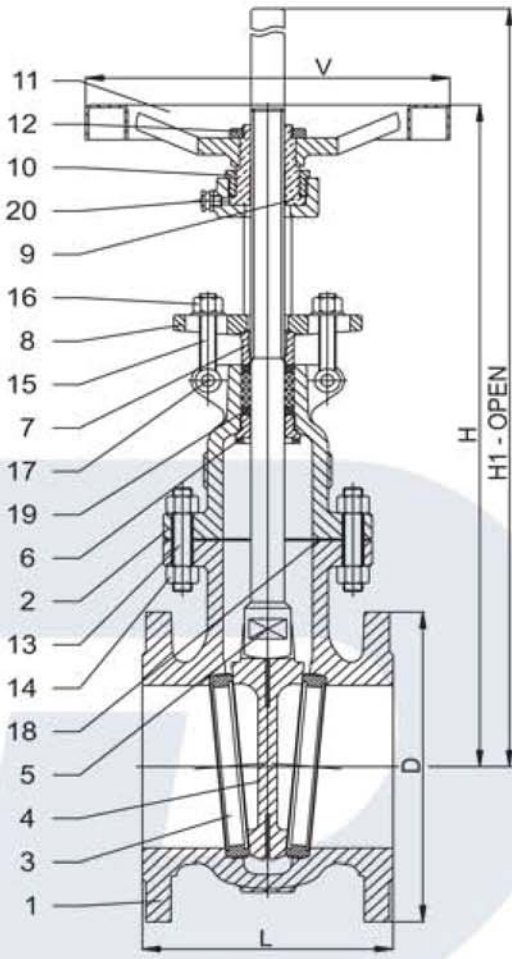

FIG. 1180 - DIN PN 16: Face to Face F4

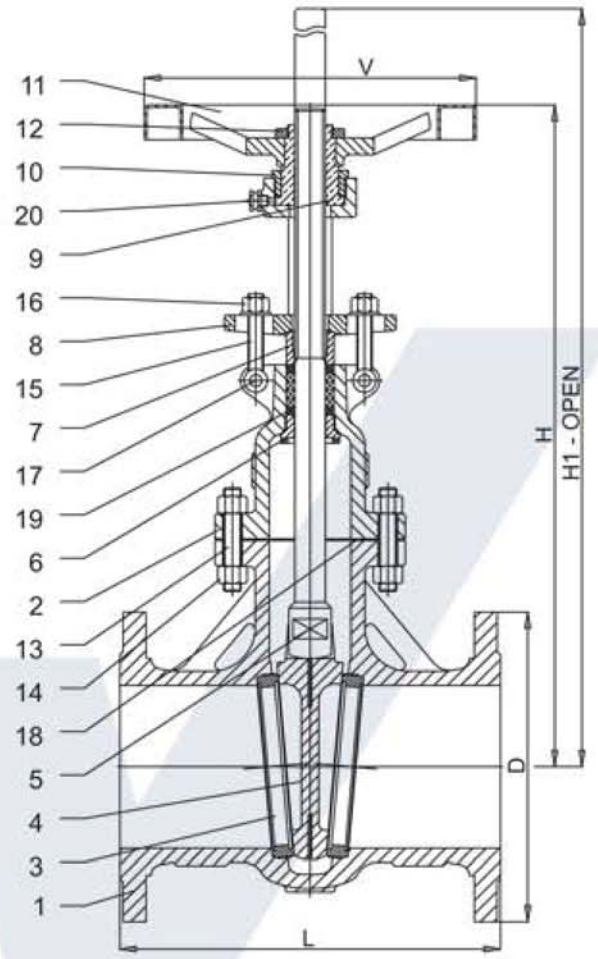

FIG. 1190 - DIN PN 16: Face to Face F5

PART NAME	A1180 - A1190	C1180 - C1190	FH1180 - FH1190	FK1180 - FK1190
1 Body	1.0619	1.7365	1.4552	1.4581
2 Bonnet	1.0619	1.7365	1.4552	1.4581
3 Seat ring surface	X20Cr13 (1)	X20Cr13 + HF (1)	X6CrNiTi18-10 (1)	X5CrNiMo17-12-2 (1)
4 Wedge seat surfaces	X20Cr13 (2)	X20Cr13 + HF (2)	X6CrNiTi18-10 (2)	X5CrNiMo17-12-2 (2)
5 Stem	X20Cr13 (3)	X20Cr13 (3)	X6CrNiTi18-10 (3)	X5CrNiMo17-12-2 (3)
6 Back seat	X20Cr13 (3)	X20Cr13 (3)	X6CrNiTi18-10 (3)	X5CrNiMo17-12-2 (3)
7 Gland	X20Cr13 (3)	X20Cr13 (3)	X6CrNiTi18-10 (3)	X5CrNiMo17-12-2 (3)
8 Gland flange	1.0460	X5CrNiMo17-12-2	X6CrNiTi18-10	X5CrNiMo17-12-2
9 Yoke sleeve	MS58 (4)	MS58 (4)	MS58 (4)	MS58 (4)
10 Yoke nut	1.0460	1.0460	X6CrNiTi18-10	X5CrNiMo17-12-2
11 Handwheel (*)		← Steel →		
12 Handwheel nut	1.0460	1.0460	X6CrNiTi18-10	X5CrNiMo17-12-2
13 Bolts	CK35	21CrMoV57	A2-70	A2-70
14 Nuts	C35	24CrMo5	A2-70	A2-70
15 Eye bolts	CK35	24CrMo5	A2-70	A2-70
16 Nuts	C35	24CrMo5	A2-70	A2-70
17 Eye bolt pin	CK35	24CrMo5	A2-70	A2-70
18 Gasket		← S.S. reinforced graphite (5) →		
19 Packing		← Graphite rings & wiper rings (6) →		
20 Grease nipple		← Steel →		



Demir Vana ve Kontrol Elemanları Makina San. Tic. Ltd. Şti

Merkez Ofis : İkitelli OSB PİK Dökümcüler San.Sit CA Blok No:3 Başakşehir/İstanbul

Tel : +90 212 297 57 30 Fax : +90 212 297 57 33 E-mail : dv@demirvana.com Web: www.demirvana.com

GATE VALVES SÜRGÜLÜ VANA



FIG. N. 1180 - GATE VALVES OVAL BODY DIN PN 16 - Face to Face F4

SIZE DN	50	65	80	100	125	150	200	250	300	350	400	500	600	700	800	900	--	--	--	--
L RF/BW	150	170	180	190	200	210	230	250	270	290	310	350	390	430	470	510	--	--	--	--
D	165	185	200	220	250	285	340	405	460	520	580	715	840	910	1025	1125	--	--	--	--
V	200	200	225	250	280	300	400	500	500	600	600	600	600	1000	1200	1200	--	--	--	--
H	350	420	500	520	610	700	900	1050	1200	1400	1580	1900	2300	2600	3200	4400	--	--	--	--
H1	415	495	580	620	720	840	1100	1300	1540	1750	1980	2450	3000	3500	4100	5500	--	--	--	--

FIG. N. 1190 - GATE VALVES OVAL BODY DIN PN 16 - Face to Face F5

SIZE DN	50	65	80	100	125	150	200	250	300	350	400	450	500	600	700	800	900	1000	1200	1400
L RF/BW	250	270	280	300	325	350	400	450	500	550	600	650	700	800	900	1000	1100	1200	1400	1600
D	165	185	200	220	250	285	340	405	460	520	580	640	715	840	910	1025	1125	1255	1485	1685
V	200	200	225	250	280	300	400	500	500	600	600	600	600	600	1000	1200	1200	1200	1400	1400
H	350	430	500	520	610	700	900	1050	1200	1400	1580	1750	1900	2300	2600	3200	4400	4700	5200	6200
H1	415	495	580	620	720	840	1100	1300	1540	1750	1980	2200	2450	3000	3500	4100	5500	5900	6600	7900

standard features

- Description** OVAL BODY
BOLTED BONNET
OUTSIDE SCREW AND YOKE
RISING STEM
NON RISING HANDWHEEL
FLEXIBLE WEDGE
RENEWABLE SEATS
- Design** DIN 3352
DIN 3840
- Face to face** DIN 3202
- Flanges** DIN 2501
DIN 2543
DIN 2526 FORM E
BW TO DIN 3239
- Testing** DIN 3352 Part 1
DIN 3230 Part 3
- Rating** DIN 2401
- Marking** EN 19
CE - PED
- Certificates** EN 10204 – 3.1 B

features on request

- TOP FLANGE TO ISO 5210
- GEAR OPERATOR
- CHAIN WHEEL OPERATOR
- PNEUMATIC ACTUATOR
- HYDRAULIC ACTUATOR
- ELECTRIC ACTUATOR
- POSITION INDICATOR
- LIMIT SWITCHES
- LOCKING / INTERLOCK SYSTEM
- PTFE SOFT SEATS
- STEM PROTECTION
- STEM EXTENSION
- LANTERN RING
- EXTENDED STUFFING BOX
- LIVE LOADED PACKING
- DRAIN PLUG
- BY PASS
- BW ENDS
- ANSI CONNECTIONS



Demir Vana ve Kontrol Elemanları Makina San. Tic. Ltd. Şti

Merkez Ofis : İkitelli OSB Pik Dökümcüler San.Sit CA Blok No:3 Başakşehir/İstanbul

Tel : +90 212 297 57 30 **Fax :** +90 212 297 57 33 **E-mail :** dv@demirvana.com **Web:** www.demirvana.com